

Diesel Powered Fork Lift Trucks 8,000kg – 16,000kg

Yale

DB/EB

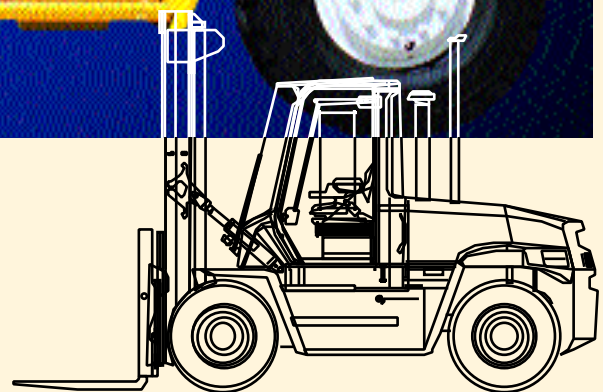

- Heavy duty trucks for demanding applications.
- Ergonomically designed cab for maximum operator productivity.
- Hydraulically actuated, load sense steering system for low steering effort.
- Large glazed cab sections, OHG design and compartment design afford excellent visibility.
- Electrically powered tilting cab and lifting engine hoods provide easy service access.



Truck Dimensions

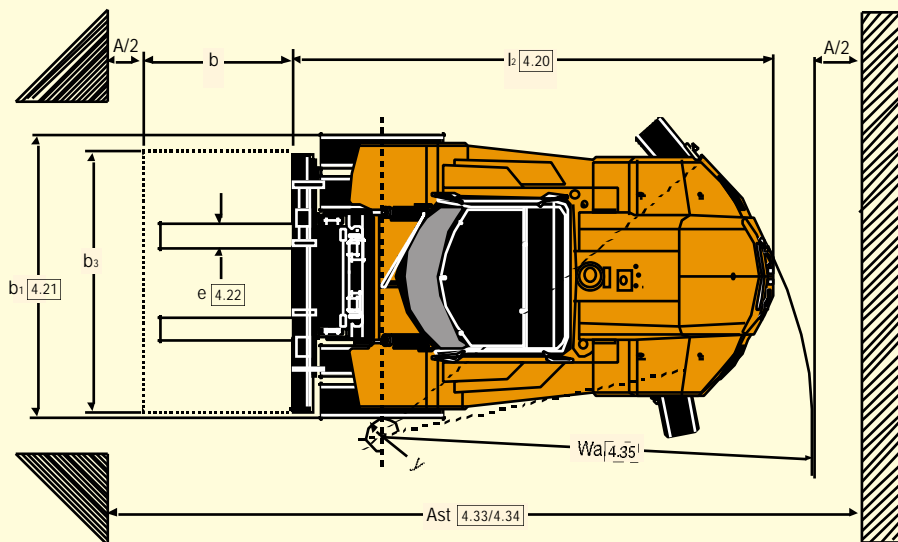
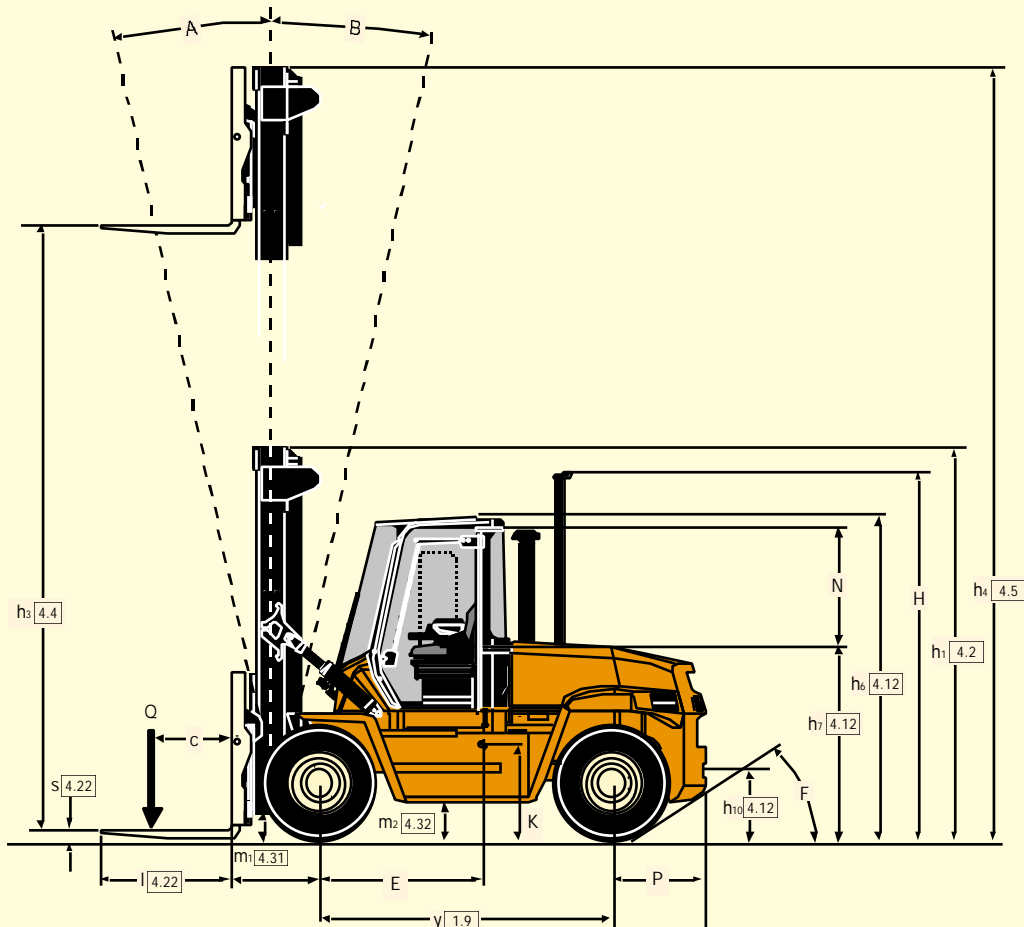

Rated Capacities

Load Centre

Distance from forks to centre of gravity of load.

Rated Load

Based on vertical masts as shown in VDI table.

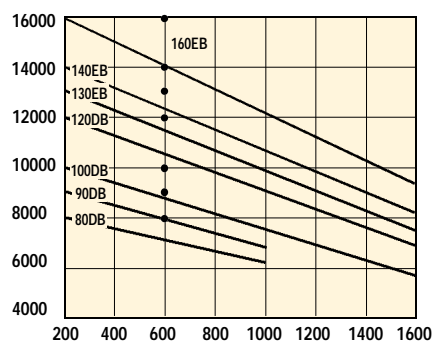

● = Centre of gravity of unladen truck
 $A_{st} = W_a + x + l_2 + a$ (see line 4.33)
 a = Minimum operating distance
 l_2 = Load length
 (VDI-standard = 200 mm BITA recommendation = 300 mm)

VDI 2198 - General Specifications

VDI 2198 - General Specifications					
Characteristics	1.1	Manufacturer		Yale	Yale
	1.2	Model designation		GDP 80 DB	GDP 90 DB
	1.3	Power: battery, diesel, LPG, electric mains		Diesel	Diesel
	1.4	Operation: stand on, rider seated		Rider-seated	Rider-seated
	1.5	Load capacity	Q (kg)	8000	9000
	1.6	Load centre	c (mm)	600	600
	1.8	Load distance (2)	x (mm)	725	725
	1.9	Wheelbase	y (mm)	2700	2700
	Weights	2.1	Unladen weight	kg	11928
2.2		Axle loadings laden, front/rear	kg	17927 / 2001	19414 / 2094
2.3		Axle loadings laden front/rear	kg	6001 / 5927	5997 / 6511
Wheels and Tyres	3.1	Tyres: C=Cushion, SC=Supercushion, P=Pneumatic		P	P
	3.2	Tyre size, front		9.00-20 12PR	9.00-20 12PR
	3.3	Tyre size, rear		9.00-20 12PR	9.00-20 12PR
	3.5	Wheels, Number front/rear (X = driven)		4x / 2	4x / 2
	3.6	Track width, front	b10 (mm)	2190	2190
	3.7	Track width, rear	b11 (mm)	1930	1930
	Dimensions	4.1	Mast tilt angle, forward / backward	Degrees	15 / 12
4.2		Height, mast lowered	h1 (mm)	4155	4155
4.3		Free lift (3)	h2 (mm)	0	0
4.4		Lift height (3)	h3 (mm)	5335	5335
4.5		Height of mast, raised; without LBE	h4 (mm)	6820	6820
4.7		Height to top of overhead guard (1)	h6 (mm)	3015	3015
4.8		Seat height	h7 (mm)	1742	1742
4.12		Towing coupling height	h10 (mm)	635	635
4.19		Overall length	l1 (mm)	5495	5495
4.20		Length to face of forks	l2 (mm)	4275	4275
4.21		Overall width	b1/b2 (mm)	2490	2490
4.22		Fork dimensions	s/e/l (mm)	65 / 200 / 1220	65 / 200 / 1220
4.23		Fork carriage DIN 15173. Class, A/B		no	no
4.24		Fork carriage width (without load backrest)	b3 (mm)	2350	2350
4.31		Ground clearance beneath mast, laden	m1 (mm)	260	260
4.32		Ground clearance, centre of wheelbase	m2 (mm)	295	295
4.33		Aisle width for pallets 1200 x 1200 wide, ⁽¹⁾	Ast (mm) per VDI	6037	6037
4.34		Aisle width for pallets 800 x 1200 long, ⁽²⁾	Ast (mm)	- - -	- - -
4.35		Outer turning radius	Wa (mm)	3912	3912
4.36		Inner turning radius	b13 (mm)	152	152
Performance	5.1	Travel speed laden/unladen	km/h	27.5 / 29.9	27.5 / 29.9
	5.2	Lifting speed laden/unladen	m/s	0.48 / 0.73	0.48 / 0.73
	5.3	Lowering speed laden/unladen	m/s	0.50 / 0.48	0.50 / 0.48
	5.5	Drawbar pull laden/unladen (60 mins.)	N (at 1.5 km/h)	82000 / 36000	82000 / 36490
	5.6	Maximum drawbar pull laden/unladen (5 mins.)	N	106000 / 36000	105000 / 36490
	5.7	Gradeability laden/unladen (30 mins.)	% (at 1.5 km/h)	46 / 32	42 / 31
	5.8	Maximum gradeability laden/unladen (5 mins.)	%	64 / 32	57 / 31
	5.9	Acceleration time laden/unladen	s (0 - 15 m)	4.0 / 3.6	4.0 / 3.6
	5.10	Service brake		hydraulic	hydraulic
	Engine	7.1	Engine manufacturer/type		Perkins / 1106C-E60TA
7.2		Engine output, in accordance with ISO 14396	kW	106	106
7.3		Governed speed	min-1	2300	2300
7.4		Number of cylinders/displacement	cm3	6 / 6000	6 / 6000
7.5		Fuel consumption in accordance with VDI cycle	l/h	8.6	8.8
Other	8.1	Drive control		torque converter	torque converter
	8.2	Operating pressure for attachments	bar	193	193
	8.3	Oil flow for attachments	l/min	93.4	93.4
	8.4	Average noise level in Cab (EN12053)	dB(A)	74+4 dB(A)	79+4 dB(A)
		Guaranteed sound power 2000/14/EC	(dB)	111	111
	8.5	Trailer coupling type		Pin	Pin

⁽¹⁾ Includes top wiper

⁽²⁾ With non- sideshift carriage

⁽³⁾ Bottom of forks



Yale	Yale	Yale	Yale	Yale
GDP 100 DB	GDP 120 DB	GDP 130 EB	GDP 140 EB	GDP 160 EB
Diesel	Diesel	Diesel	Diesel	Diesel
Rider-seated	Rider-seated	Rider-seated	Rider-seated	Rider-seated
10000	12000	13000	14000	16000
600	600	600	600	600
755	755	846	846	846
2900	2900	3300	3300	3300
14144	15787	16669	17826	18710
21548 / 2596	25060 / 2727	27219 / 2450	29060 / 2766	31741 / 2969
6875 / 7269	7453 / 8334	8523 / 8146	8926 / 8900	8730 / 9980
P	P	P	P	P
10.00-20 14PR	10.00-20 14PR	11.00-20 14PR	12.00-20 16PR	12.00-20 16PR
10.00-20 14PR	10.00-20 14PR	11.00-20 14PR	12.00-20 16PR	12.00-20 16PR
4x / 2	4x / 2	4x / 2	4x / 2	4x / 2
2190	2190	2276	2276	2276
1930	1930	2000	2000	2000
15 / 12	15 / 12	15 / 12	15 / 12	15 / 12
4455	4455	4443	4466	4466
0	0	0	0	0
5330	5330	5310	5310	5310
7120	7120	7120	7120	7120
3033	3033	3043	3064	3064
1760	1760	1770	1791	1791
653	653	663	684	684
5725	5725	6364	6364	6484
4505	4504	4994	4994	5114
2490	2490	2617	2617	2617
70 / 200 / 1220	70 / 200 / 1220	90 / 20 / 1370	90 / 200 / 1370	90 / 200 / 1370
no	no	no	no	no
2350	2350	2500	2500	2500
280	280	206	227	227
315	315	325	346	346
6235	6235	6825	6825	6932
---	---	---	---	---
4080	4080	4579	4579	4686
255	255	444	444	444
28.0 / 30.4	27.0 / 30.0	23.5 / 26.5	23.8 / 26.7	25.1 / 26.6
0.34 / 0.53	0.34 / 0.53	0.29 / 0.44	0.29 / 0.44	0.29 / 0.44
0.49 / 0.46	0.49 / 0.46	0.48 / 0.44	0.48 / 0.44	0.48 / 0.44
80000 / 41385	79000 / 44945	94000 / 51400	88000 / 52900	88000 / 53800
100000 / 41385	100000 / 44945	121000 / 51400	115900 / 52900	115400 / 53800
36 / 31	31 / 30	34 / 33	30 / 32	25 / 31
47 / 31	39 / 30	46 / 33	40 / 32	36 / 31
4.0 / 3.7	4.0 / 3.9	4.0 / 3.8	4.1 / 4.0	4.2 / 4.1
hydraulic	hydraulic	hydraulic	hydraulic	hydraulic
Perkins / 1106C-E60TA	Perkins / 1106C-E60TA	Perkins / 1106C-E60TA	Perkins / 1106C-E60TA	Perkins / 1106C-E60TA
106	106	106	106	106
2300	2300	2300	2300	2300
6 / 6000	6 / 6000	6 / 6000	6 / 6000	6 / 6000
9	10	11	12	13
torque converter	torque converter	torque converter	torque converter	torque converter
193	193	193	193	193
93.4	93.4	93.4	93.4	93.4
79+4 dB(A)	76+4 dB(A)	79+4 dB(A)	79+4 dB(A)	79+4 dB(A)
111	107	107	107	107
Pin	Pin	Pin	Pin	Pin

Mast details and capacity ratings (kg) - Pneumatic tyres								
Model					GDP 80 DB		GDP 90 DB	
Tyres					9.00 - 20 12PR		9.00 - 20 12PR	
Width across tyres					2490		2490	
Mast	OAH h1	MFH TOF	Free Lift TOF	h4	Forks	Integral Sideshift	Forks	Integral Sideshift
					600	600	600	600
					LC	LC	LC	LC
2-Stage (V)	3330*	3750*	-	5240*	8600	8000	9500	9000
	3780*	4650*	-	6140*	8600	8000	9500	9000
	4150*	5400*	-	6890*	8600	8000	9500	9000
3-Stage FFL	3025*	5600	1400	7030	7320	6780	8280	7700
	3158*	6000	1533	7430	7580	6740	8230	7630
	3325*	6500	1700	7930	7230	6650	8050	7560
	3491*	7000	1866	8430	7010	6580	7870	7500

Mast details and capacity ratings (kg) - Pneumatic tyres								
Model					GDP 100 DB		GDP 120 DB	
Tyres					10.00 - 20 14PR		10.00 - 20 14PR	
Width across tyres					2490		2490	
Mast	OAH h1	MFH TOF	Free Lift TOF	h4	Forks	Integral Sideshift	Forks	Integral Sideshift
					600	600	600	600
					LC	LC	LC	LC
2-Stage (V)	3620	3750	-	5470	10400	10000	12700	12000
	4070	4650	-	6370	10400	10000	12700	12000
	4450	5400	-	7120	10400	10000	12700	12000
	4850	6200	-	7920	10400	10000	12400	12000
	5100	6700 ⁽¹⁾	-	8420 ⁽¹⁾	10200	9700	12400	11700
3-Stage FFL	3045	5600	1435	7030	10060	9650	11990	11470
	3178	6000	1568	7430	10030	9610	11960	11410
	3345	6500	1735	7930	9860	9770	11790	11330
	3511	7000	1901	8430	9640	9240	11200	11120

Mast details and capacity ratings (kg) - Pneumatic tyres										
Model					GDP 130 EB		GDP 140 EB		GDP 160 EB	
Tyres					11.00 - 20 14PR		12.00 - 20 16PR		12.00 - 20 16PR	
Width across tyres					2617		2617		2617	
Mast	OAH h1	MFH TOF	Free Lift TOF	h4	Forks	Integral Sideshift	Forks	Integral Sideshift	Forks	Integral Sideshift
					600	600	600	600	600	600
					LC	LC	LC	LC	LC	LC
2-Stage (V)	3640 ⁽²⁾	3750 ⁽²⁾	-	5470 ⁽²⁾	13600	13000	14600	14000	16700	16000
	4090 ⁽²⁾	4650 ⁽²⁾	-	6370 ⁽²⁾	13600	13000	14600	14000	16700	16000
	4460 ⁽²⁾	5400 ⁽²⁾	-	7120 ⁽²⁾	13600	13000	14600	14000	16700	16000
	4860 ⁽²⁾	6200 ⁽²⁾	-	7920 ⁽²⁾	13500	13000	14500	14000	16550	16000
	5110 ⁽²⁾	6700 ⁽²⁾	-	8420 ⁽²⁾	13300	12700	14250	13720	16300	15650
3-Stage FFL	3070 ⁽²⁾	4400	1300	6080	12790	11950	13730	12840	15600	14630
	3270 ⁽²⁾	5000	1500	6680	12750	11910	13680	12800	15560	14590
	3600 ⁽²⁾	6000	1830	7680	12680	11840	13610	12730	15490	14520
	3940 ⁽²⁾	7000	2160	8680	12200	11410	13150	12290	14810	14060

*Add 20mm if optional 10.00-20 tyres are fitted ⁽¹⁾ Restricted back tilt required ⁽²⁾ Deduct 20mm for GDP 130 EB model h4 - Top of carriage (extended height)
Model GDP 80-90EB, forks 200x65x1220. Model GDP 100-120EB, forks 200x75x1220. Model GDP 130-160EB, forks 200x90x1400.

Load Moment							
Model	GDP 80 DB	GDP 90 DB	GDP 100 DB	GDP 120 DB	GDP 130 EB	GDP 140 EB	GDP 160 EB
Load moment cm-kg	1060 000	1192 500	1355 000	1626 000	1879 800	2024 400	2313 600
Dimensions (mm)	E	1342	1405	1490	1531	1613	1760
	F	35°	35°	37°	37°	41°	37°
	H	3388	3388	3411	3411	3440	3463
	K	1080	1050	1160	1120	1210	1180
	N	1135	1135	1135	1135	1135	1135
	P	848	848	848	848	848	968

Models:

GDP80DB, 90DB, 100DB, 120DB
GDP130EB, 140EB, 160EB

Engines

The Perkins turbo charged diesel engine features a direct fuel injection with fast ram combustion for improved fuel efficiency / power and reduced exhaust emissions. The engine features a Thermostart cold start system and is tier 2 emissions legislation compliant. The engine and transmission protection system features a warning light, buzzer and shut down.

Cooling System

The cooling system utilizes a 508mm diameter 8 blade puller fan, a fan shroud and a corrugated fan radiator for maximum cooling efficiency.

Electrical System

DB/EB models feature A 24 volt electrical system and a 80amp alternator with an internal regulator.

The instrument cluster is enclosed in a moulded housing and mounted to the right of the operator, at a convenient angle. The gauges are backlit for brighter imaging at low light conditions. The cluster is comprehensively equipped and includes a LCD hour meter and error code display for the transmissions electronics.

Transmission

The fully automatic 3 speed Autoshift transmission with high ratio torque converter matches the engine to the tractive power requirements to give exceptional tractive and travel speed performance. CANbus technology transmits system signals between truck controls, the transmission and the instrumentation. Direction is controlled by a forward / reverse hand lever on the steering column. Yale Foot Direction Control is available and provides improved load handling efficiency and easier operator control.

Brakes

The wet disc wheel speed brakes are designed for accurate and low effort brake actuation and control. A separate wet brake oil cooler is used with an oil temperature-warning sensor to provide the operator with an early indication of excessive oil temperature.

The pinion mounted dry disc park brake is applied and released via a control button located on the right hand side instrument console.

Hydraulic system

The tandem hydraulic pumps operate at 193 bar. All hydraulic fittings include flat face O-ring seals to help eliminate hydraulic leaks. Small hydraulic lines and components allow for easy maintenance

access. Electro mechanical solenoids allow precise control of oil flow during hoist and tilt functions and provide excellent load control.

Computerised settings for hydraulics and transmission can be precisely adjusted via Yale software.

Steering

The hydrostatic steering system is all hydraulic and is designed to give precise, reliable control. The load sensing system provides low steering effort and good performance at all engine speeds. The axle design has large sealed bearings, precision machine parts and non-adjustable tie-rods and provides a durable and low maintenance system.

Mast

The heavy-duty mast absorbs forward and back load forces and provides constant lowering speeds to reduce potential product damage. The nested channel design incorporates full-face load rollers for durability. Rolled mast channels and formed cross members provide high strength. Anti cavitation tilt control valves prevent drift and provide precise mast positioning. The lift cylinders are positioned behind the mast channel for maximum visibility through the mast.

Maintenance and Service Access

The electrically powered cab tilt system gives unrivalled access to major components. The cab tilts 30 degrees for a quick check, and full tilt for major repairs.

The engine compartment hoods lift up and lock in place making routine maintenance and daily checks fast and easy. The hoods can be completely removed for maximum service access.

The low position and length of the running boards further aids access to major components.

The battery box is located in the right side running board for maximum service access.

Operators Compartment, Controls and Instrumentation

The cab is ergonomically designed for maximum operator productivity. Its spacious dimensions promote driver comfort and productivity. Three low profile steps, dual full length handrails and the open floor design ease entry and exit.

The 3 speed high capacity heating system provides all round heating / cooling. Air from the outside is filtered to provide a cleaner environment for the operator.

Ventilation is provided by sliding windows, alternatively both doors can be left open using the open door latch for maximum ventilation. Air conditioning is available.

The large curved glazed areas offer excellent visibility, while angled overhead guard bars maximise overhead visibility. Front, rear and top wipers with washer, plus front and rear window demister are standard. The console is located in the driver's right hand side putting the controls within easy reach, maximising forward low-level visibility and minimizing instrument reflections.

The steering wheel with spinner knob and centrally mounted horn is adjustable for both rake angle and height. 4 LEDs mounted in the steering column serve as a warning light to alert the driver of any malfunction indicated by the display in the right hand side console.

The foot controls consist of an accelerator pedal, a combined inching / brake pedal and a brake pedal.

Hydraulic functions are operated by lever controls, with a joystick optionally available. Electro-proportional hydraulic control valves ensure smooth and effortless use of lever controls. The controls are mounted on the armrest and are adjustable independently of the seat. The armrest maintains its position in relation to the seat when the seat is adjusted.

The cab is positioned on four large anti-vibration mounts to protect the operator from shock, noise and vibration.

The full suspension seat is fully adjustable to suit the desired working position. The steer column has a wide, stepless adjustment range for both rake angle and height.

Wide-angle side view mirrors are provided in the top left and right hand front corners of the cab.

Cab options:

- Air conditioning with roller type sunblind mounted in roof
- Roller type sunblind mounted in roof
- Open cab
- Rain top for open cab
- Hydraulic joystick with horn button
- Map reading light
- Sun shade
- Recirculation fan to provide additional air circulation
- Operator training seat
- Sound reduction



Yale Europe Materials Handling
Flagship House, Reading Road North,
Fleet, Hampshire GU51 4WD, United Kingdom.
Tel: + 44 (0) 1252 770700 Fax: + 44 (0) 1252 770780
www.yale.com



Safety. This truck conforms to the current EU requirements. Specification is subject to change without notice

Publication part no. 258985879 Rev.02
Printed in The United Kingdom (050410/878HG) EN

Yale is a registered trade mark.
© Yale Europe Materials Handling 2004. All rights reserved.

Truck shown with optional equipment